

JCB JS131 LC Hydraulic Excavator

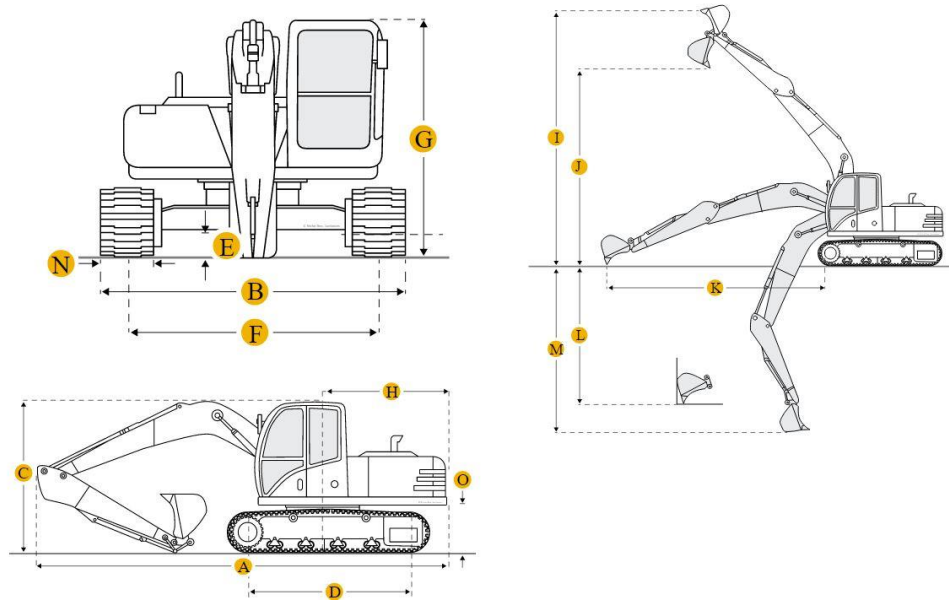

Dimensions

Dimensions

E Ground Clearance	1.4 ft in
G Height To Top Of Cab	9.34 ft in
B Width To Outside Of Tracks	8.17 ft in
D Length Of Track On Ground	9.4 ft in
H Tail Swing Radius	7.01 ft in
F Track Gauge	6.53 ft in
O Counterweight Clearance	2.97 ft in
Tailswing Radius	7.01 ft in
Transport Height	112.88 in
Transport Length	295.87 in
Undercarriage Overall Length	11.83 ft in

Undercarriage

Track Adjustment	Grease cylinder type.
Number Of Shoes Per Side	44

Specifications

Slew System	
Slew Motor	Axial piston type
Slew Brake	Hydraulic braking plus automatic spring applied disc type parking brake
Slew Torque	36.2 KNm
Slew Speed	13.3 rpm
Slew Gear	Large diameter, internally toothed fully sealed grease bath lubricated.

Engine	
Air Filter Type	Dry
Starting System	24 V
Battery	2 x 12 V
Fuel Tank	58.2 gal
Engine Model	JCB EcoMAX 444 TCA 55 EU Stage IIIB, EPA Tier 4 Final compliant
Engine Type	Water cooled, 4-stroke, 4-cylinder in-line, common rail injection, turbocharged fixed geometry intercooled diese